

Firstmetal®

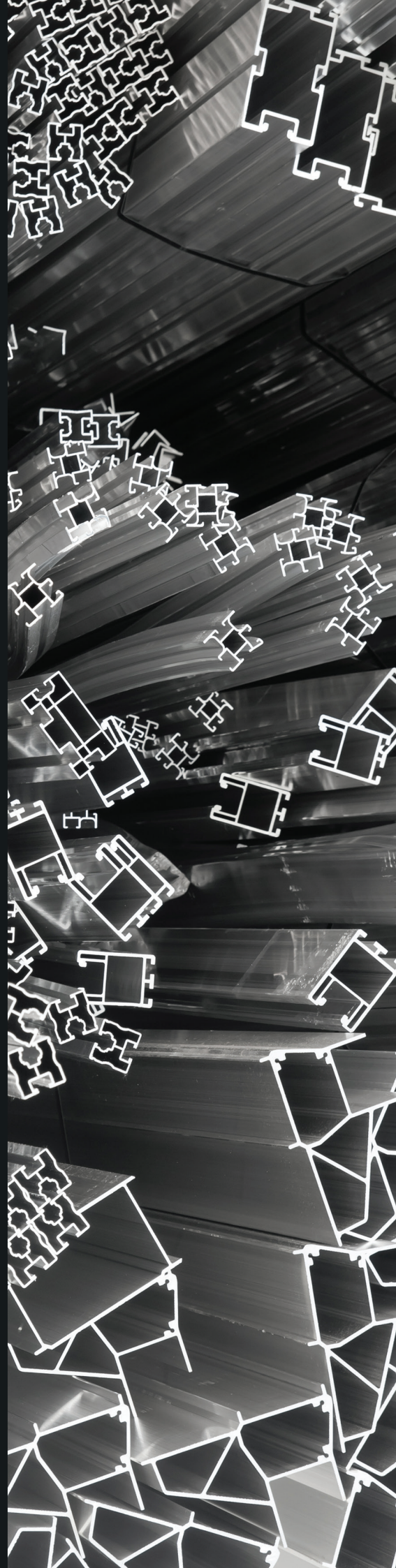

GENERAL CATALOGUE

ALUMINIUM EXTRUSION PROFILES
GENERAL CATALOGUE
2019/2020 ...



Mechanical Properties & Chemical Composition of Alloy AA6063, AA6061 & AA6082 in temper T5 & T6

International Standard Compliance

Extrusion Dimension Tolerance: BS EN 755 Series, DIN 1748, DIN 17615, ASTM B221

	Alloy AA 6063	Alloy AA 6061	Alloy AA 6082
% Mg	0.45-0.90	0.80-1.20	0.62-0.70
% Si	0.20-0.60	0.40-0.80	0.95-1.05
% Cr	0.10	0.04-0.35	0.02
% Zn	0.10	0.25	0.02
% Fe	0.35	0.70	0.16-0.22
% Cu	0.10	0.15-0.40	0.03
% Mn	0.10	0.15	0.50-0.57
% Ti	0.10	0.15	0.02
Other impurities	0.05	0.05	0.02
Aluminium	REMAINDER	REMAINDER	REMAINDER

International Standard Compliance

	Alloy 6063		Alloy 6061		Alloy 6082	
	T5	T6	T5	T6	T5	T6
Ult. Tensile Strength	150	185	190	280	290	310
0.2% Proof stress	110	160	115	240	270	285
Hardness (Brinell)	55	75	60	90	70	95
Ult. Shear Strength	155		205		211	
Elongation on 50mm	8		8		10	
Density	3		3		3	
Melting Range	600-650		580-650		580-650	
Coefficient on Linear Expansion	23		24		24	
Modules of Elasticity	67000		69000		69000	
Fatigue Strength (50x10 ⁶)	75		95		101	

TEMPER

T4 : Solution heat treatment & naturally aged to a substantially stable condition

T5 : Cooled from an elevated temperature Shaping process and then artificially aged hardened.

T6 : Solution heat treatment and age hardened.

FIRE RATING :

Aluminium Alloys non “combustible” and rated AA (the highest possible under the classification system - BS 476: Part 6.

EXTRUSION PRESS SIZES

1. 20 MN Press Billet diameter 203 mm (8)inches

MAXIMUM SIZE OF PROFILE

Solid : 240 mm CCD (Circumscribing Circle diameter)

Hollow : 200 mm CCD (Circumscribing Circle diameter)

ALLOY CHARACTERISTIC

AA 6063 : The most popular extrusion alloy , takes a good surface finish, is corrosion resistant and can be heat treated or strength.

AA 6061: Most versatile alloy of heat treatable group is an improved magnesium silicide alloy with the ability to develop strength somewhat higher used in transportation & structural applications than 6063 alloy - good corrosion resistant –used in transportation and structural applications.

AA 6082: Similarly this alloy has good tensile strength having good extrudability; widely chosen for Auto mobile profiles structures with complex sections,

Saraya Hinged Window 1.3mm Wall Thickness

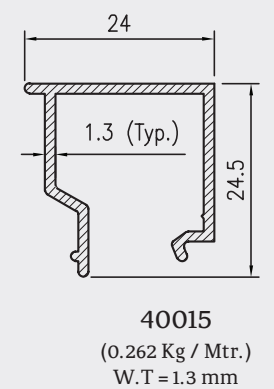
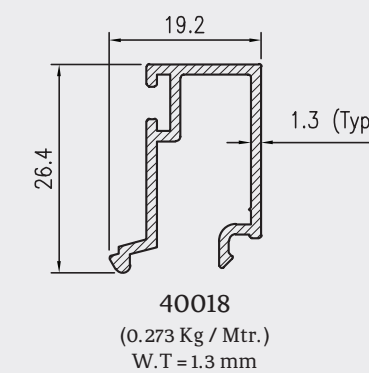
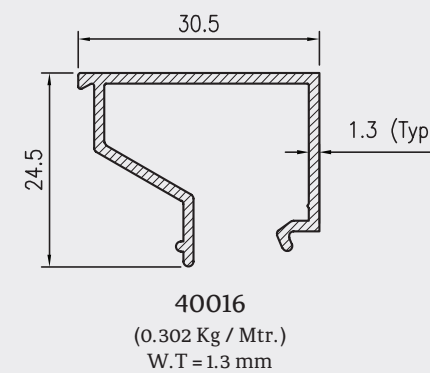
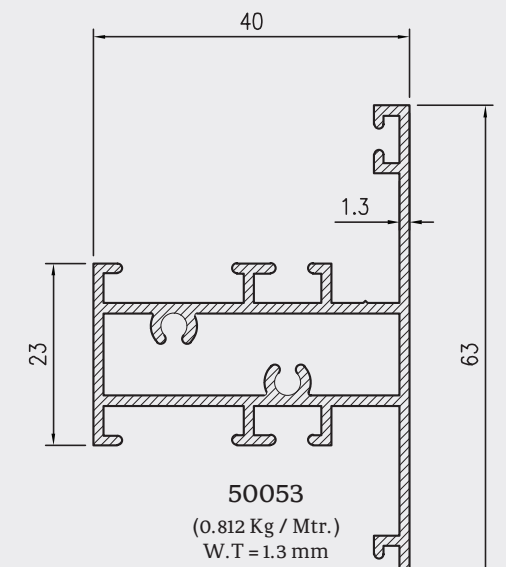
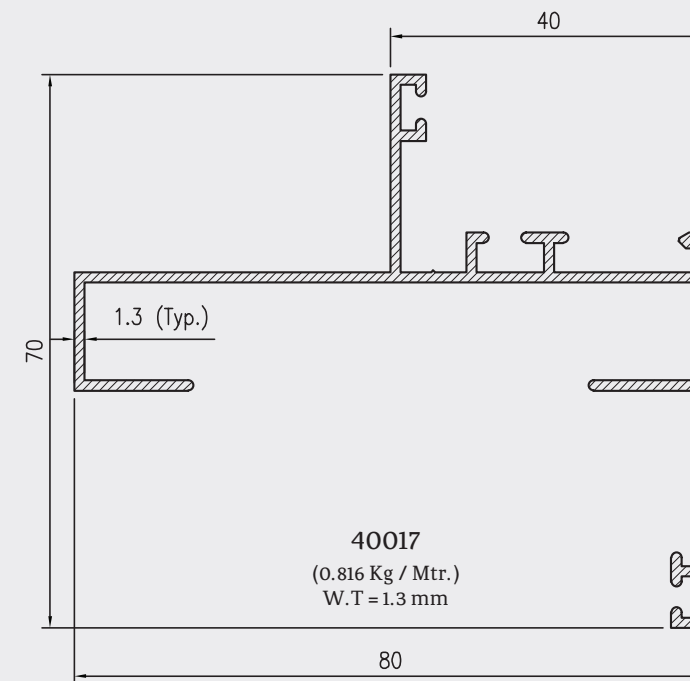
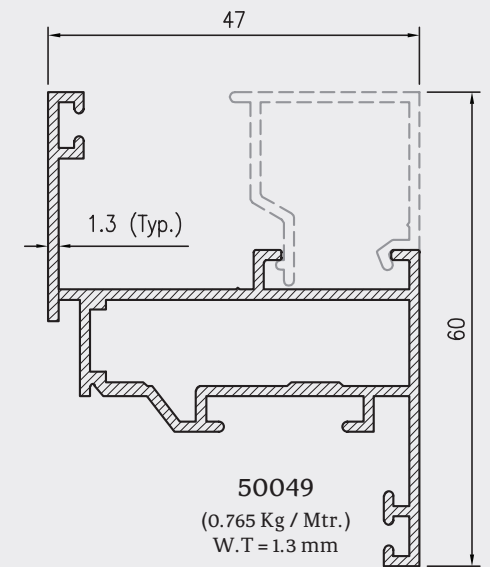
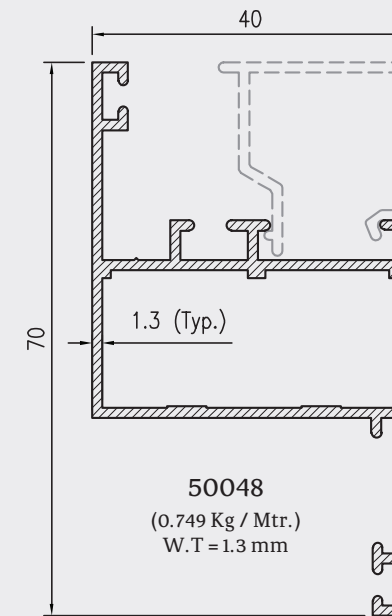

SARAYA CASEMENT SERIES



Saraya Hinged Door 1.3mm Wall Thickness

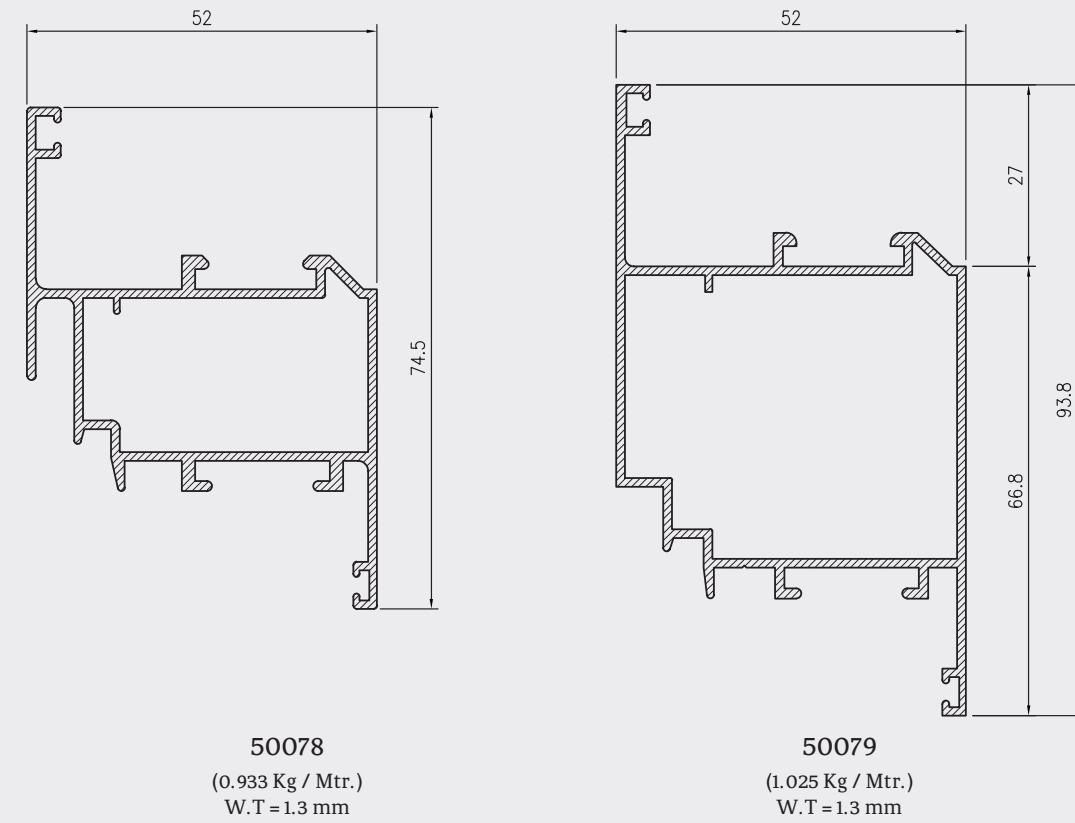
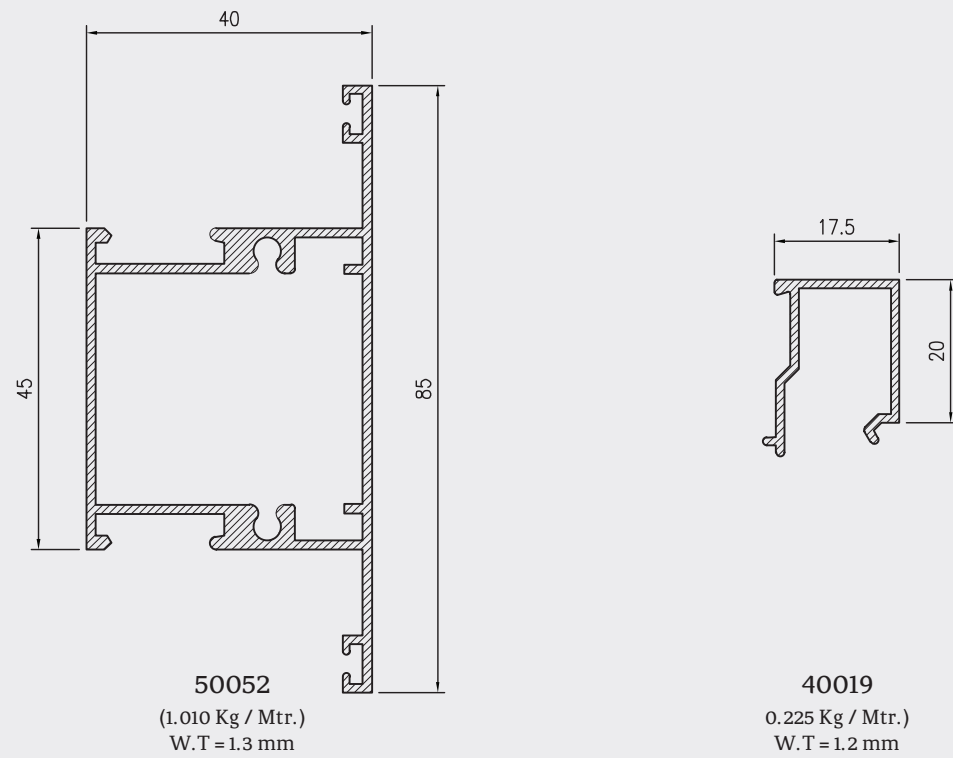
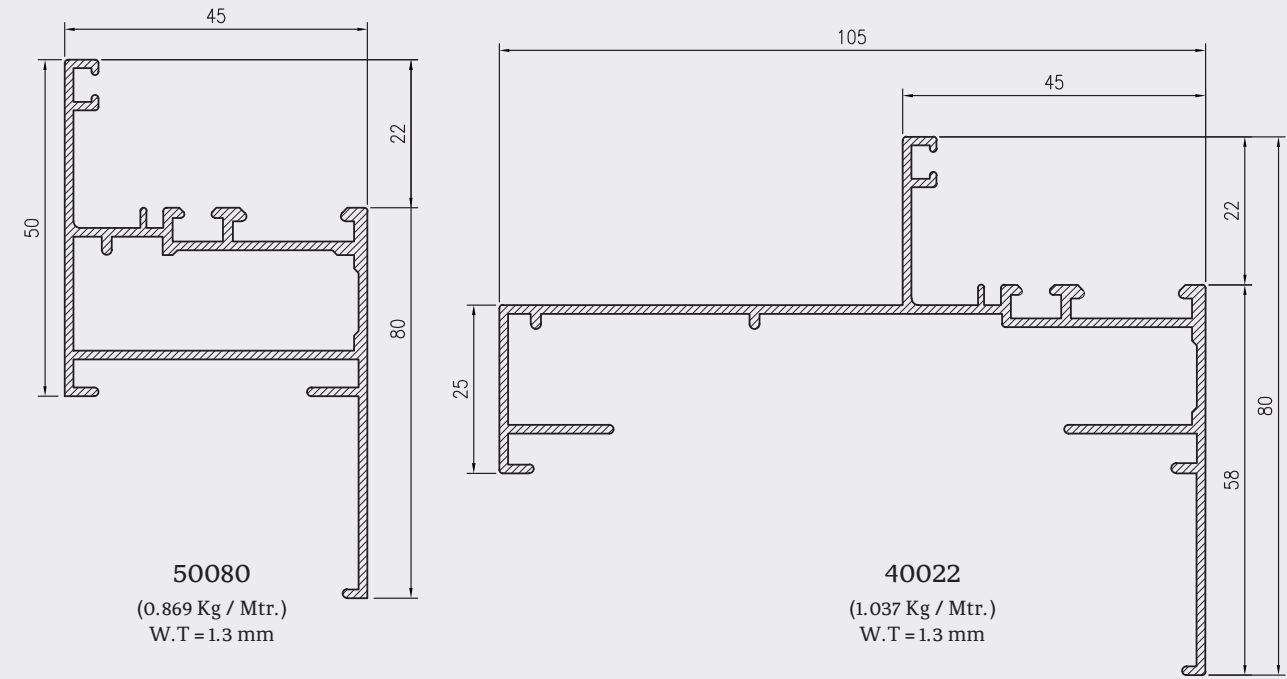
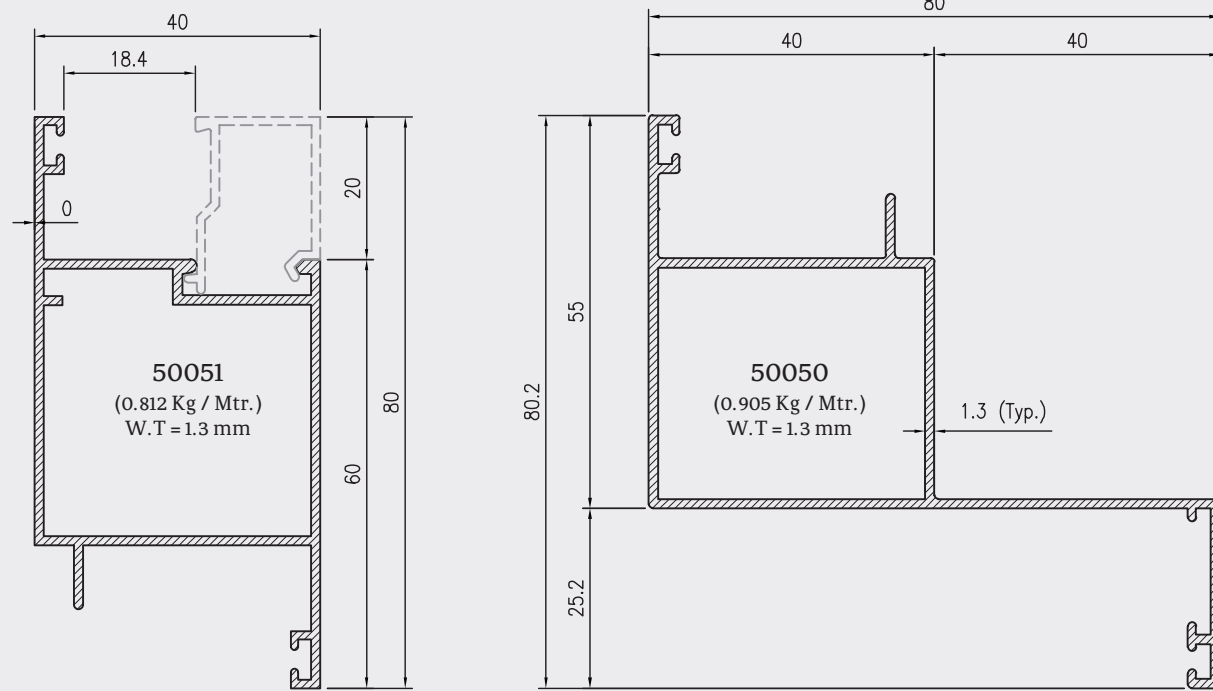

COMMERCIAL
CASEMENT 42MM SERIES(TIJARI)
0.9MM & 1.0MM THICKNESS



Commercial Hinged Windows & Doors

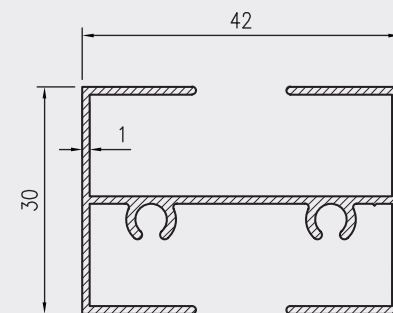
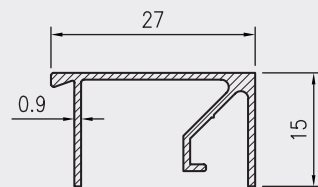
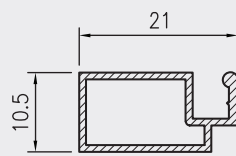
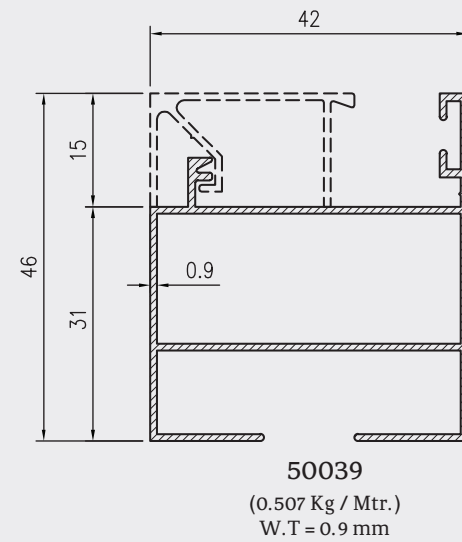
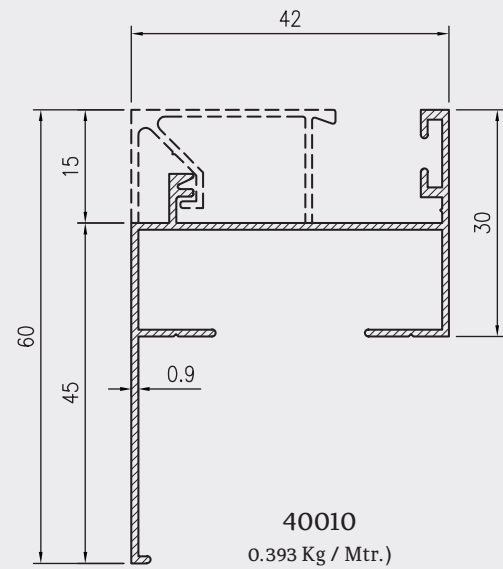
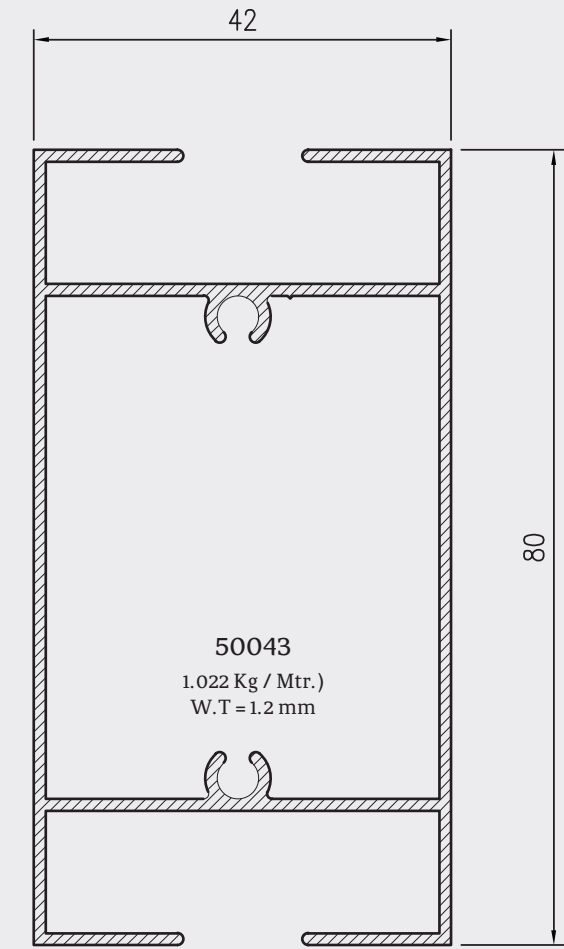
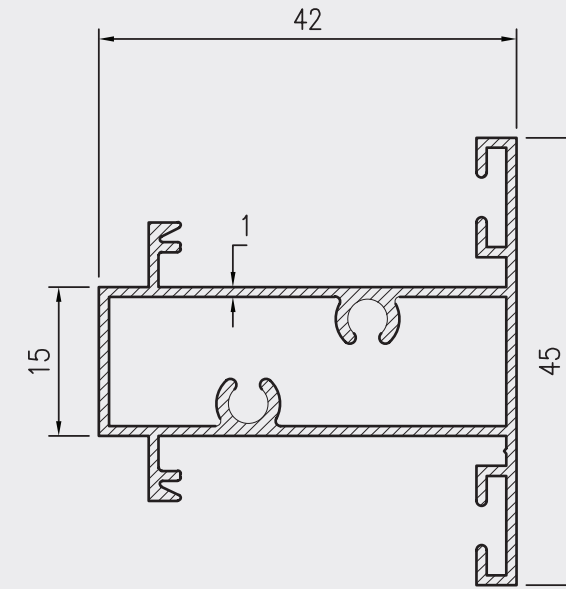
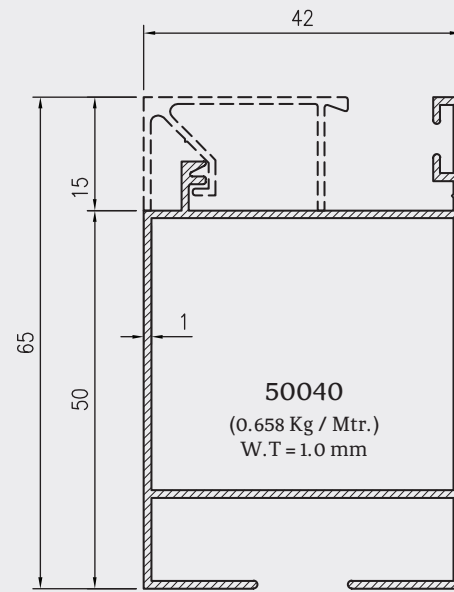
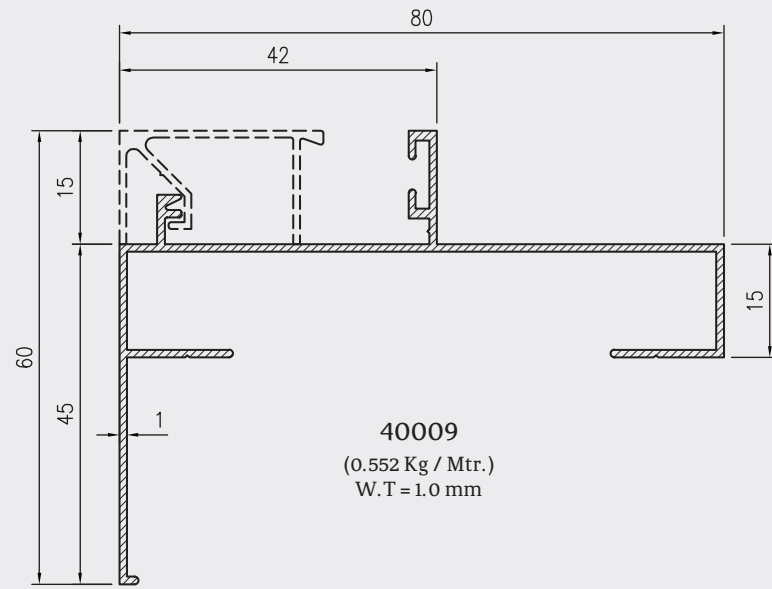

Firstmetal[®]

Rabigh Industrial Area Phase 3, Rabigh 21911 –Kingdom of Saudi Arabia
Factory Tel: +966 12 636 5252 Fax: +966 12 636 7771 Email: info@fmic.com.sa
Website: www.fmic.com.sa